



SONOMA CAST STONE / 877.283.2400

COMMERCIAL BATH PRODUCTS

Visit www.sonomastone.com to see photos.
Designs ©2009 Sonoma Cast Stone Corp. All rights reserved.

MODEL: TROUGH - COMMERCIAL - ADA

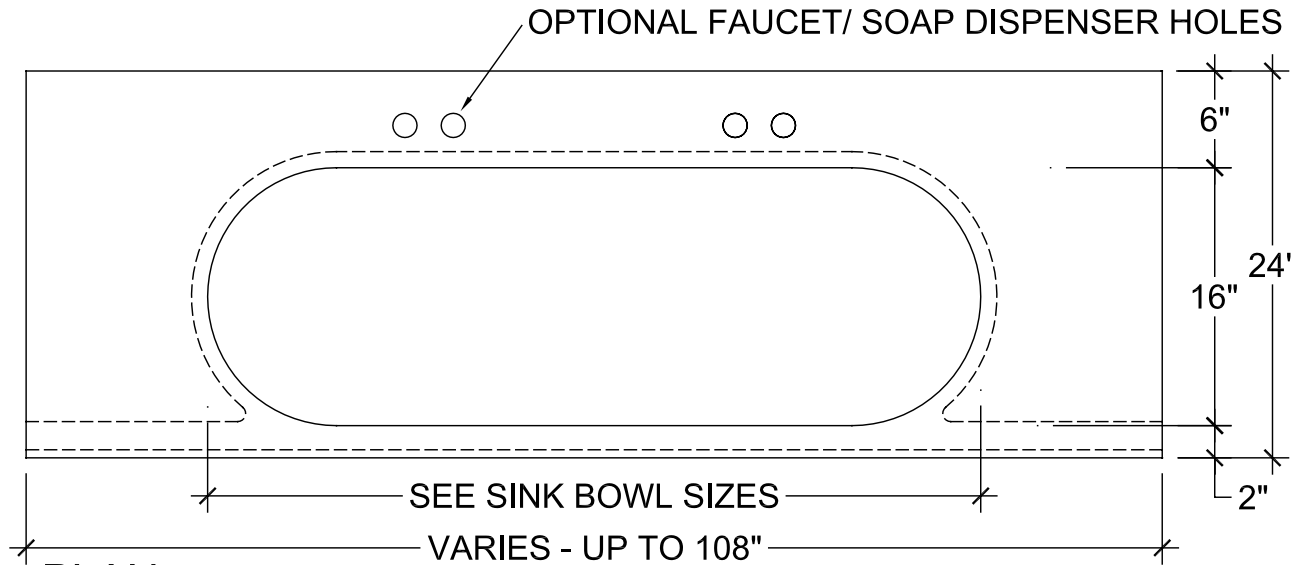

PLAN

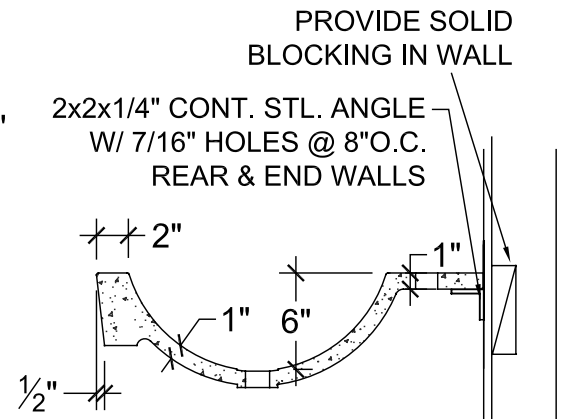

SECTION @ DRAIN

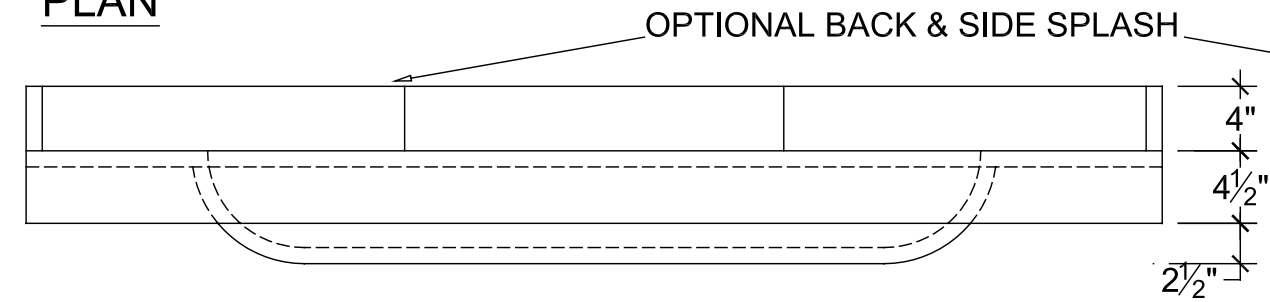

FRONT ELEVATION

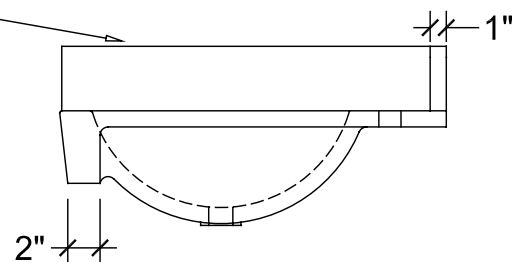

RIGHT ELEVATION