

WV-TUB-60 (INDULGE URBAN)

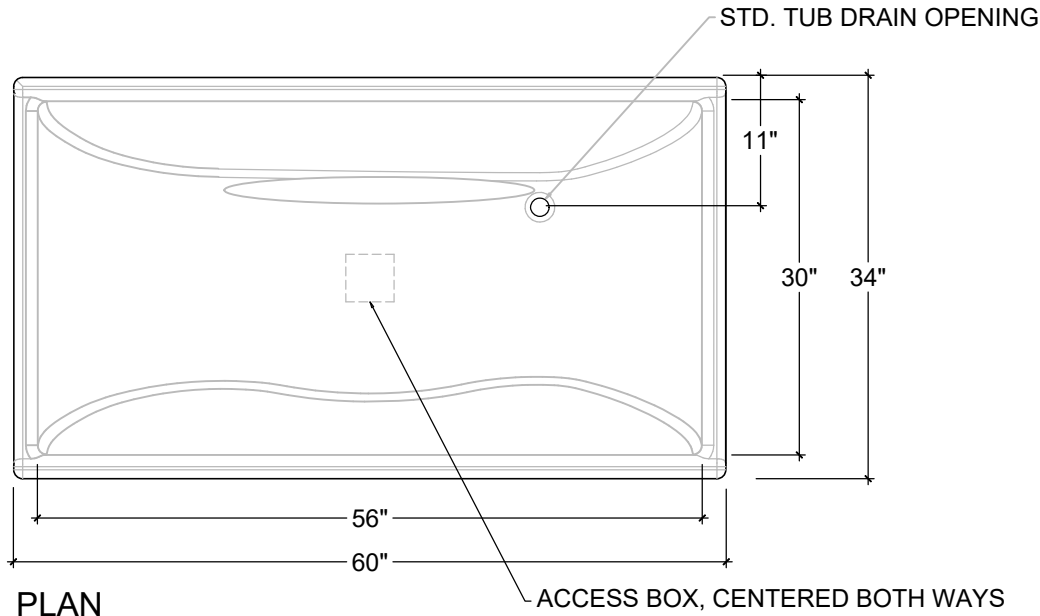

CAPACITY: 85 GALLONS (3" FROM RIM)  
 APPROXIMATE DRY WEIGHT: 1,580LB.  
 FILLED WEIGHT 2,260LB

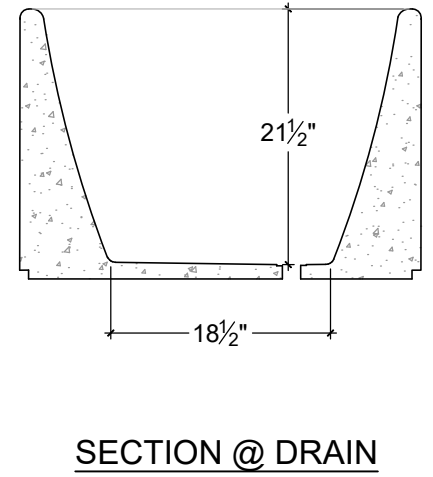
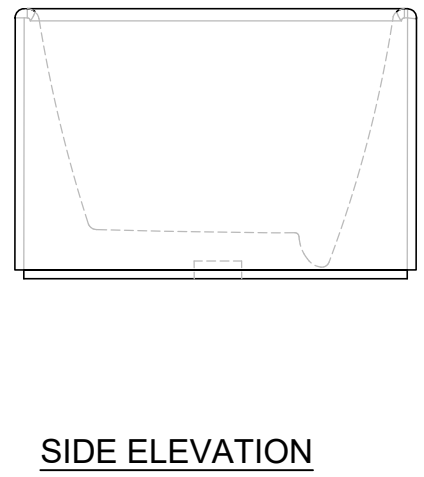
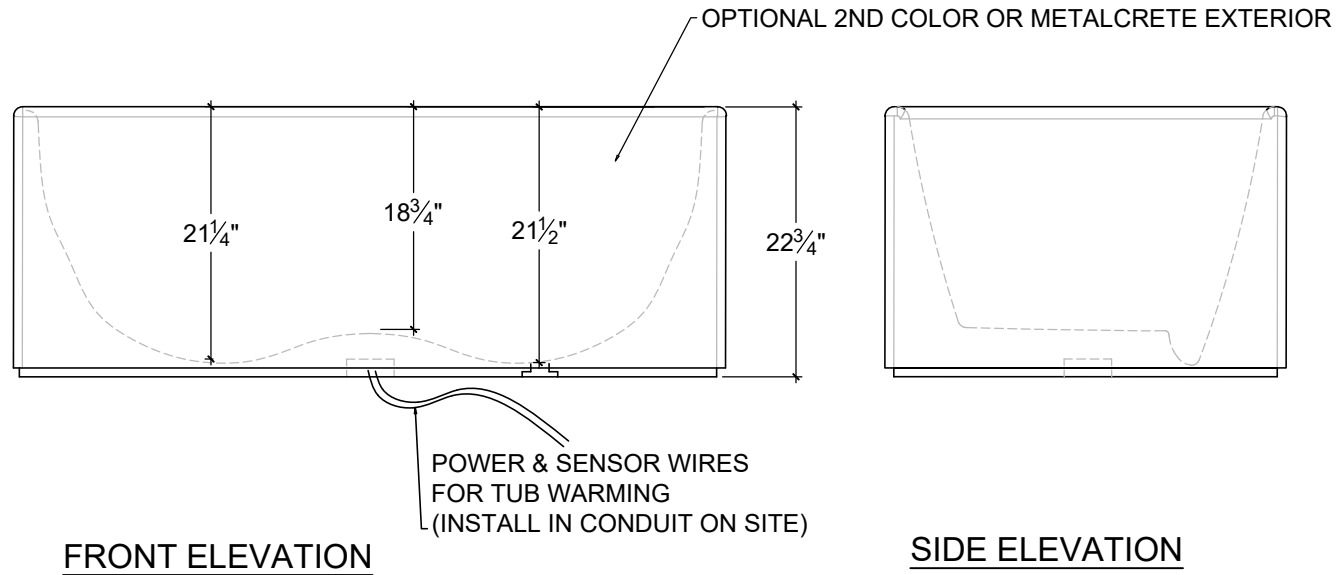

INDULGE TUB, URBAN  
 CUSTOM BASIN MOLDS AVAILABLE

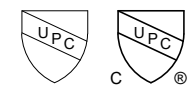

IAPMO Certificate of Listing #4816

(877)283-2400  
 www.sonomastone.com  
 sales@sonomastone.com  
 All rights reserved