

WV-TUB-DB-C

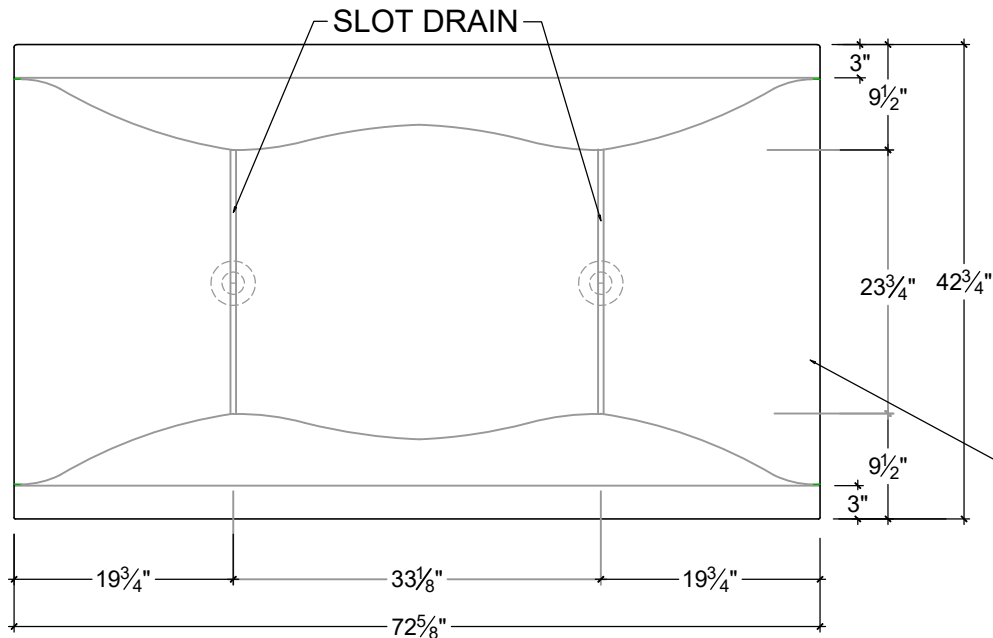

CAPACITY: 130 GALLONS
 APPROXIMATE DRY WEIGHT: 1,800LB
 FILLED WEIGHT: 2,840LB



END OF WAVE RECESSED 1/4" BELOW SIDE RIM

PLAN

FAUCET & OVERFLOW/
 DRAIN OPTIONAL
 BY SONOMA FORGE
 WWW.SONOMAFORGE.COM

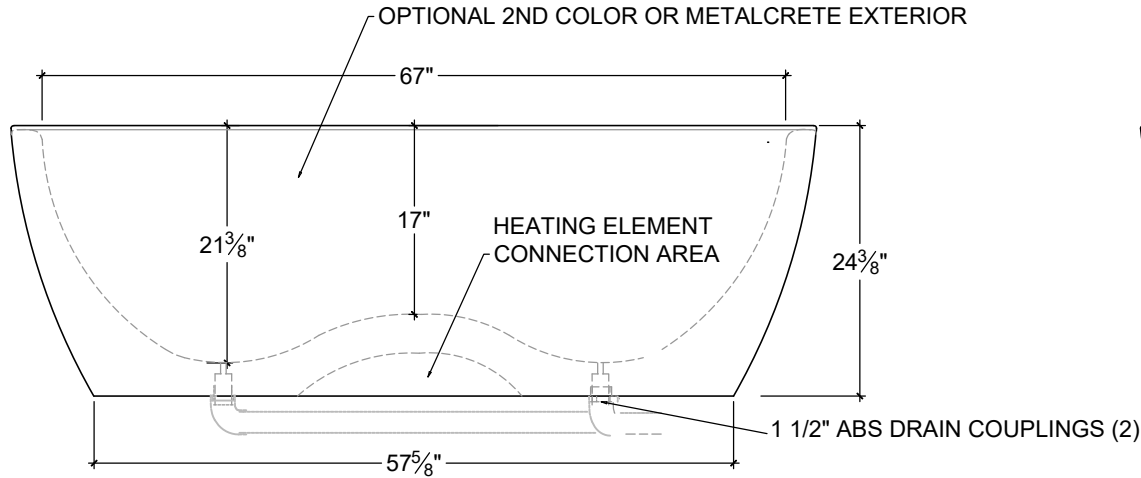

FRONT ELEVATION

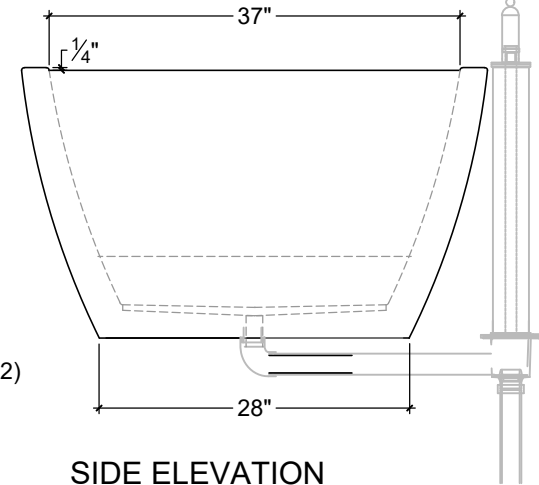

SIDE ELEVATION



DOUBLE WAVETUB
 STANDARD EXTERIOR

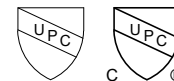

IAPMO Certificate of Listing #4816

(877)283-2400
 www.sonomastone.com
 sales@sonomastone.com
 All rights reserved